

CANopen ABSOLUTE MULTI-TURN ENCODERS, PHM9 RANGE

PHM9, 90mm encoder, the new generation of CANopen multi-turn encoder:

- Heavy Duty version, 11 & 12 mm solid shaft.
- Robustness and excellent resistance to shocks / vibrations.
- High protection level IP65.
- High performances in temperature -20°C to +85°C.
- Universal electronic circuits from 5 to 30Vdc.
- High resolutions available: 8192 (13 bits) per turn.
- Turn counting up to 65 536 (16 bits).
- Available with incremental channels – 2048 points – 5 to 30 Vdc.
- Also available with SSI, Profibus and RS232 interface.

CANopen
DS 301 V4.02
DS 406 V3.1



PHM9_12 connection BCR (M23 radial)

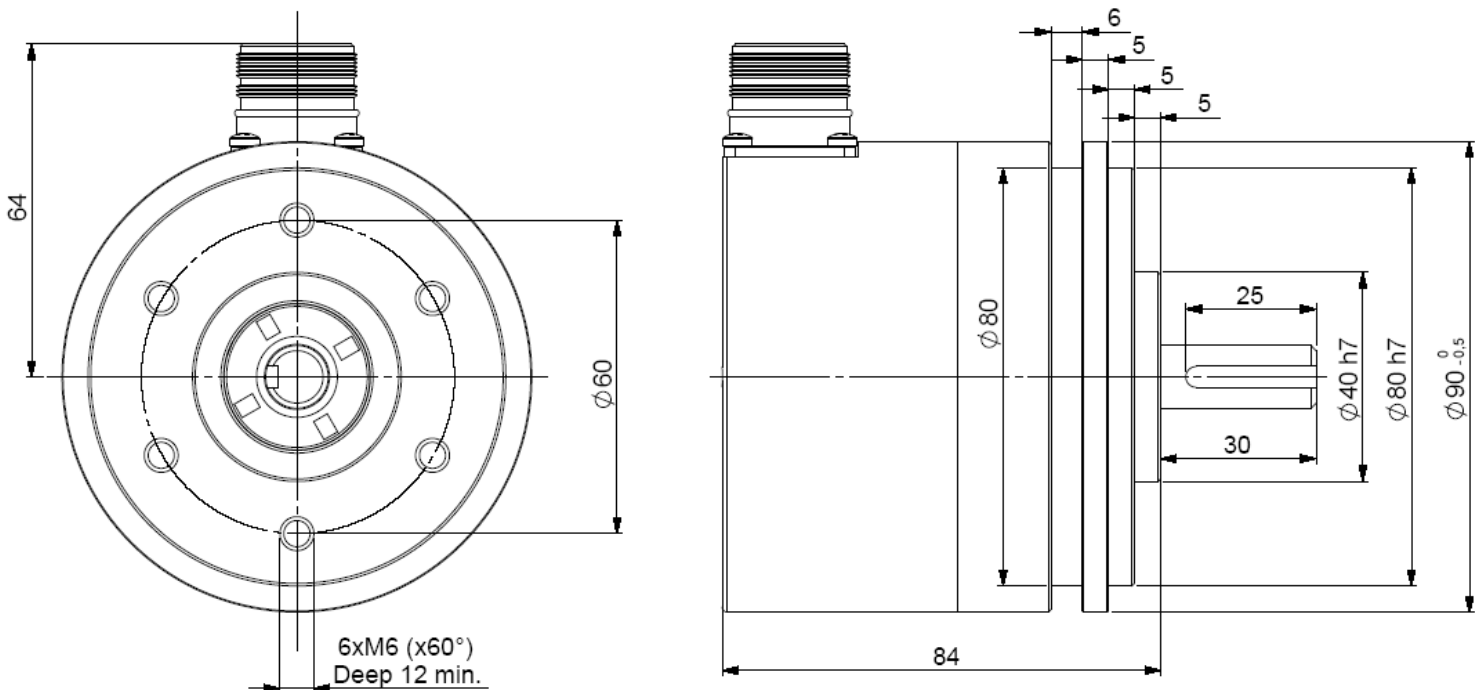

MECHANICAL CHARACTERISTICS

Material	Cover : steel	Shocks (EN60068.2.27)	≤ 500m.s ⁻² (during 6 ms)	
	Body: aluminium	Vibrations (EN60068.2.6)	≤ 100m.s ⁻² (10 ... 2 000 Hz)	
Shaft	Stainless steel	EMC	EN 61000-6-4, EN 61000-6-2	
Bearings	6001 serie	Isolation	100V (1 min.)	
Maximal loads	Axial : 100 N	Encoder weight (approx.)	1,600 kg	
	Radial : 200 N	Operating temperature	- 20 ... + 85 °C (encoder T°)	
Shaft inertia	≤ 15.10 ⁻⁶ kg.m ²	Storage temperature	- 20 ... + 85 °C	
Torque	≤ 10.10 ⁻³ N.m	Protection(EN 60529)	IP 65	
Permissible max. speed	6 000 min ⁻¹	Theoretical mechanical lifetime 10 ⁹ turns (F _{axial} / F _{radial})		
Continuous max. speed	6 000 min ⁻¹	20 N / 30 N	50 N / 100 N	100 N / 200 N
Shaft seal	Viton double lips	360	18	2,2

CANopen ABSOLUTE MULTI-TURN ENCODERS, PHM9 RANGE

ELECTRICAL CHARACTERISTICS

Power supply	5 – 30Vdc
Introduction	< 1 s
Consumption (without load)	< 50mA (at 24Vdc)
Accuracy	± ½ LSB (13 bits)

Programmable parameters

Resolution: defines the resolution per revolution (0 to 8 192),

Global resolution : total amount of codes for the encoder (2 to 536 870 912),

Transmission speed : programmable from 10kbaud (1000m) to 1 Mbaud (40 m) ; value per default: 20 Kbaud,

Address: define the software address of the encoder on the bus (1 to 127, value by default: id = 1),

Direction : define the direction of count of the encoder ,

RAX : defines the value of its preset position (non turning shaft),

CAM: Low and High Limits.

Communication modes

3 modes are available to interrogate the encoder :

POLLING mode: (Response to a RTR message): The position value is only given upon request (SDO mode),

CYCLIC mode: the encoder transmits its position in an asynchronous manner. The frequency of the transmission is defined by the programmable cyclical timer register from 0 to 65 535 ms,

SYNCHRO mode: the encoder transmits its position on a synchronous demand by the master.

CANOPEN CONNECTION

1	2	3	4	5	6	7	8, 9, 11	10	12
Reserved	CAN LOW	CAN GND	Reserved	Reserved	Reserved	CAN HIGH	Reserved	0V	+ 5/30Vdc

Pinout 3 (CAN GND) and 10 (0V) are connected together (intern the encoder).

Nota : Refer to the bus standards for the maximal derivation length.

ORDERING CODE (Special versions upon request, for ex. special flanges/electronics/connections...)

	Shaft Ø	Power supply	Output stages	Code	Resolution	Nb of turns	Connection	Connection orientation
PHM9	12 12mm	P : 5 to 30Vdc	BB : CANopen	B : Binary	13 : 8192 points per turn (2 ¹³)	B16 : 65 536 turns (2 ¹⁶)	BC: M23 12 pinouts clockwise	R : radial
PHM9	12 //	P	BB	B //	13	B16 //	BC	R

Made in France