

MAGNETIC ENCODERS - CANOPEN ABSOLUTE MULTI TURN - TXM4 RANGE



TXM4 is a Ø42mm multiturn encoder with CANOpen interface :

- Compact and robust design.
- Heavy-duty conception : Stainless steel – IP69K
- Solid shaft Ø 10 mm version.
- Precision sealed bearings.
- High temperature performance –30°C to 85°C.
- Hall effect technology.
- Multiturn encoding based on magnetic pulse counter. No batteries used.
- CANOpen interface, binary code.
- 12 bits resolution = 4096 steps / turn.
- Number of turns : 12 bits = 4096 turns.
- Polarity inversions and surges protections.
- High integration SMD technology.



DIMENSIONS TXM4S10 M12 AXIAL

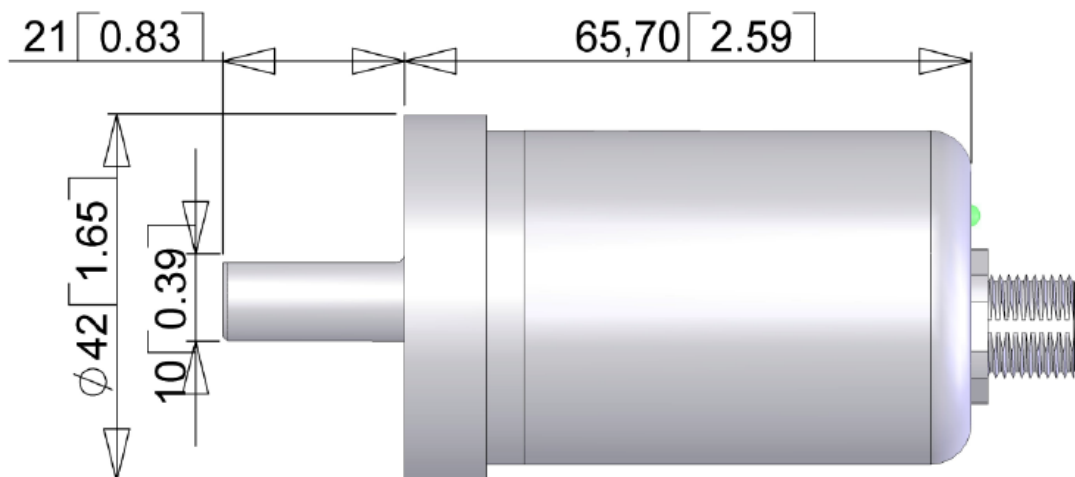

all dimensions mm [inch]

MECHANICAL CHARACTERISTICS

Material	Cover : stainless steel	Vibrations (EN 60068-2-6)	≤ 30 g (10Hz... 1 000Hz)		
	Body : stainless steel	Weight	350 g		
	Shaft: stainless steel	Operating temperature	- 30 ... + 85°C		
Max. shaft loading	Axial : 270 N	Storage temperature	- 30 ... + 85°C		
	Radial : 270 N	Humidity	98 % without condensation		
Shaft Inertia	≤ 30 g.cm ²	Protection class (EN 60529)	IP 69K		
Torque	≤ 3 N.cm	Lifetime in 10 ⁸ revolutions with F _a / F _r (axial / radial)			
RPM (continuous operation)	12 000 rpm	100 N / 100 N	270 N / 270 N	300 N / 300 N	
Shock (EN 60068-2-27)	≤ 300 g (half-sine, 6 ms)	200	10	7.6	
Shock (EN 60028-2-29)	≤ 30 g (half-sine, 16ms)				

MAGNETIC ENCODERS - CANOPEN ABSOLUTE MULTI TURN - TXM4 RANGE



ELECTRICAL CHARACTERISTICS

Interface	According to ISO 11898	Consumption	max 50mA at 24Vdc
Transmission	Max 1 MBauds	Accuracy	+/- 0,35°
Internal cycle time	< 1mss	EMC	EN 61000-6-4 EN 61000-6-2
Supply	10 – 30Vdc	Electrical life-time	> 10 ⁵ h

TRANSMISSION MODES

POLLED mode	By a remote-transmission-request telegram the connected host calls for the current process value. The absolute rotary encoder reads the current position value, calculates eventually set-parameters and sends back the obtained process value by the same identifier
CYCLIC mode	The absolute rotary encoder transmits cyclically - without being called by the host - the current process value. The cycle time can be programmed in milliseconds for values between 1 ms and 65536 ms
SYNC mode	After receiving a sync telegram by the host, the absolute rotary encoder answers with the current process value. If more than one node number (encoder) shall answer after receiving a sync telegram, the answer telegrams of the nodes will be received by the host in order of their node numbers. The programming of an offset-time is not necessary. If a node should not answer after each sync telegram on the CAN network, the parameter sync counter can be programmed to skip a certain number of sync telegrams before answering again.

PROGRAMMABLE PARAMETERS

Operating Parameters	This parameter determines the counting direction, in which the output code increases or decreases. As an important operating parameter the code sequence (complement) can be programmed
Resolution per turn	Value between 1 and 4096 can be programmed
Total resolution "Max range"	This parameter is used to program the desired number of measuring units over the total measuring range. This value may not exceed the total resolution of the absolute rotary encoder.
Preset Value	The preset value is the desired position value, which should be reached at a certain physical position of the axis
Limit Switch, Min. and Max	Two position values can be programmed as limit switches. By reaching these values one bit of the 32 bit process value is set to high level

CONFIGURATION

The standard configuration is : node number = 32 and Baurate = 125kBaud. These configurations can be modified with SDO frames. The Baudrate can be modified from 20kBaud to 1MBaud. The node number can be programmed between 0 and 89.

CANopen CONNECTION

Type	GND	+Ub = 10-30Vdc	CAN-High	CAN-Gnd	CAN-Low
B7	3	2	4	1	5

ORDERING REFERENCE (specific manufacture on demand. ex: flange / specific connection...)

TXM4S	10	/	AA	/	5	BB	B	//	12B12	//	B7A
Absolute multiturn encoder	Solid shaft Ø10mm		Stainless steel & IP69K		Supply : 11 to 30Vdc	CANopen	Binary code		12bits : resolution 12 bits : number of turns		M12.5 pinouts axial output